



Ideally suited for picking works

- Adjustable-height tray with an edge to drop and pick parcels and parts
- Saloon-style doors for an easier access to the platform

Optimum compactness

- Width of 76 cm to operate in the most congested areas

Exceptional productivity

- Driveable at full height
- Load capacity up to 180 kg
- High Operating Autonomy
- Robust, reliable, easy to maintain

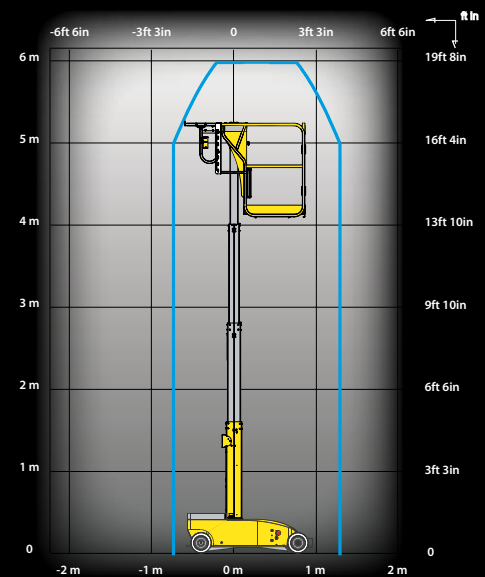

STAR 6 Picking

VERTICAL MASTS

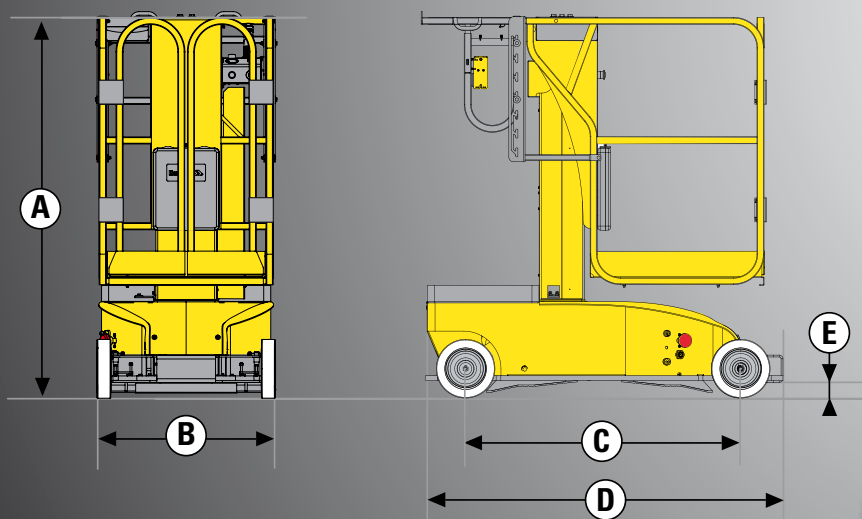

TECHNICAL DATA

STAR 6 Picking

Working Height	6 m
Platform Height	4 m
Horizontal outreach	N/A
Lift capacity	180 kg
Platform size	0.69 x 0.74 m
Picking tray size	0.45 x 0.74 m
Picking tray lift capacity	90 kg
D - Length	1.5 m
B - Width	0.76 m
A - Height - stowed	1.65 m
Tailswing	N/A
C - Wheelbase	1.17 m
E - Ground Clearance	7.5 cm
Drive speed proportional	0.5 - 5 km/h
Turning radius - outside	1.5 m
Turntable rotation	N/A
Tilt alarm	2°
Gradeability	20 %
Tires - non marking	250x60
Power source	24V - 185 Amph (C5)
Weight	820 kg

STANDARD EQUIPMENT

- Adjustable-height picking tray with 4 positions
- Electric proportional controls for a soft and very progressive driving
- Electric continuous engine
- 2 back drive-wheels
- 2 front steer-wheels
- Deep-cycle batteries
- Battery charge indicator
- Battery charger with automatic stop
- Non-marking tires
- Tilt controller
- Brake release
- Manual platform lowering valve
- Towing hooks
- Horn
- Hourmeter

OPTIONS AND ACCESSORIES

- Flashing light
- Travel alarm
- Remote control for brake release
- Electric socket in the platform
- Biodegradable hydraulic oil
- Cold temperature hydraulic oil



Haulotte 
GROUP