

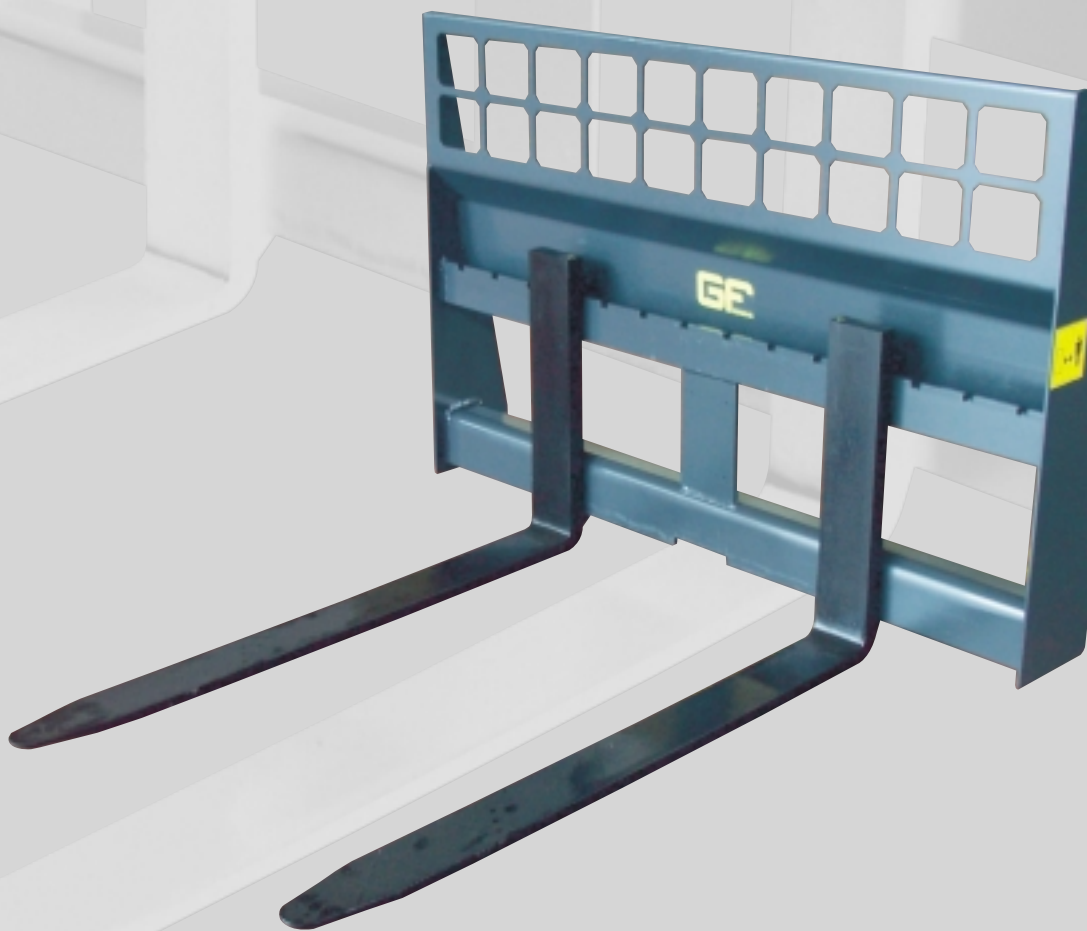

FORCA PALLET per skid-steer loaders

Pallet forks for skid-steer loaders



CARATTERISTICHE TECNICHE

Technical specification

| Modello Model | PF 100 | PF 120 | PF 130 | PF 150 |
|---|--------|--------|--------|--------|
| Portata massima* Max carrying capacity* Q (Kg) | 800 | 1000 | 1500 | 2000 |
| Baricentro Centre of gravity B (mm) | 500 | 500 | 500 | 500 |
| Lunghezza forche Fork Length C (mm) | 900 | 1000 | 1100 | 1200 |
| Sezione forca Fork section F (mm) | 30 | 30 | 35 | 40 |
| Sezione forca Fork section E (mm) | 80 | 80 | 100 | 100 |
| Larghezza Width L (mm) | 1000 | 1200 | 1300 | 1500 |
| Altezza Height H (mm) | 900 | 950 | 950 | 950 |
| Massa totale Total Weight (kg) | 115 | 145 | 185 | 230 |

* La portata massima indicata è riferita ad un carico avente baricentro (B), posizionato in modo centrato su entrambe le forche

* The indicated maximum carrying capacity refers to loads positioned with the centre of gravity (B) between the forks

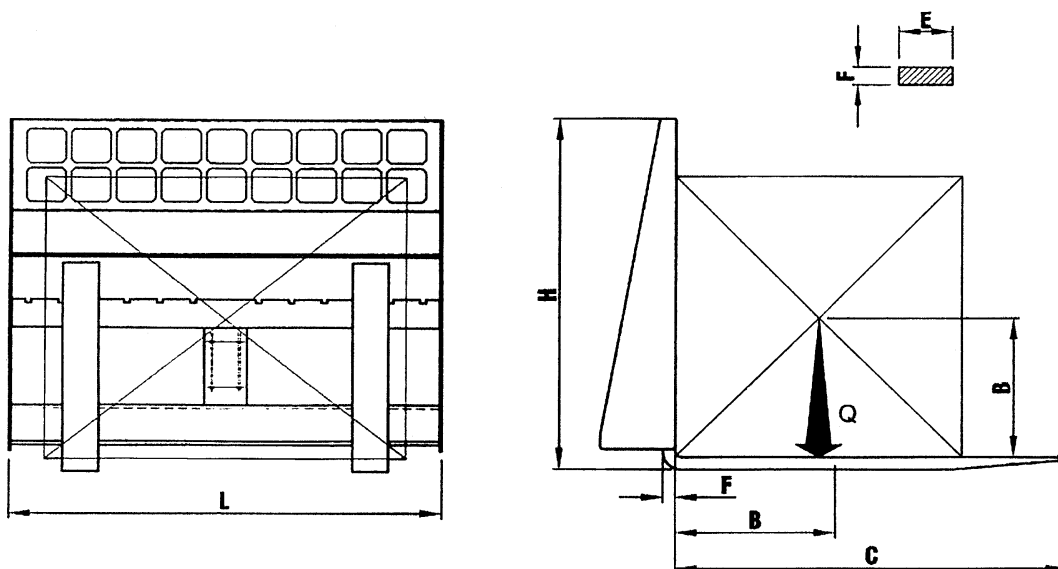

Dati e illustrazioni sono forniti a titolo informativo e non impegnativo - Data and descriptions are in any way not binding



G.F. di Gordini F. e Figlio snc
Via Cà del Vento, 35 - 48012 Bagnacavallo (RA) Italy
tel. +39 0545 62712 fax +39 0545 62140
gfgordini@gfgordini.com • www.gfgordini.com

Spazio per il rivenditore

ACCESSORI PER MACCHINE OPERATRICI